

Distributed Generation Interconnection Policy

A guide for contractors and homeowners for residential and small commercial
grid-tied power generation



Introduction

Coastal Electric Cooperative (herein after referred to as “Coastal” or the “Cooperative”) is a not-for-profit cooperative created to provide the best possible service to its Members. In efforts to provide great service, Coastal Electric Cooperative is providing a Distributed Generation Interconnection Policy, allowing the Member to connect his own electric power generation in parallel with the Cooperative’s system. This Distributed Generation Interconnection Policy establishes the terms and conditions for the interconnection and metering of distributed generation facilities.

Definitions

The following words and terms shall have the following meanings unless the context clearly indicates otherwise:

1. **“Billing period”** means, as to a particular Member, the time period between the dates on which the Cooperative normally reads the retail service meter for billing purposes.
2. **“Bidirectional meter”** is a meter capable of measuring (but not necessarily displaying) electricity flow in both directions.
3. **“Bidirectional metering”** means using one meter to measure the amount of electricity supplied by the Cooperative and the amount of electricity fed back to the Cooperative by the Member’s distributed generation facility.
4. **“Member Generator”** means a Member of the Cooperative who owns and operates a distributed generation facility.
5. **“Distributed generation facility”** means a facility owned and operated by a Member of the Cooperative for the production of electrical energy that:
 - a. Uses a solar photovoltaic system, fuel cell, or wind turbine; and
 - b. Has peak generating capacity of not more than 10 kWAC for a residential application and 100 kWAC for a commercial application; and
 - c. Is located on the Member’s premises; and
 - d. Operates in parallel with the Cooperative’s distribution facilities; and
 - e. Is connected to the Cooperative’s distribution system via the Member’s side of the Cooperative’s retail service meter; and
 - f. Is intended primarily to offset part or all of the Member generator’s requirements for

electricity.

6. “**Excess Energy**” is the difference between the electricity generated by the distributed generation facility and the electricity consumed by the Member during the billing period.

Availability

The Cooperative will purchase energy from distributed generation facilities on a first come, first served basis, only until the cumulative generating capacity of all renewable resources equals 0.2% of the Cooperative’s previous year’s non-coincident peak demand. The allowable capacity of distributed generation facilities for residential Members shall not exceed 10 kWAC. The allowable capacity of distributed generation facilities for non-residential Members shall not exceed 100 kWAC.

Type of Service

Distributed generation interconnection is available to 60-cycle services at one of the following approximate voltages:

1. Single-Phase, 120/240 Volts, or
2. Three-Phase, 208Y/120 Volts, 480Y/277 Volts, or
3. Three-Phase, three-wire, 240/480 Volts

The type of service supplied will depend upon the voltage available. Prospective Member generators should ascertain the available voltage by inquiring at the Cooperative’s office before purchasing equipment. Three-phase voltage, other than the foregoing, is subject to mutual agreement between the Cooperative and the Member. Other types of installations may be permitted, subject to approval by the Cooperative.

Bidirectional Metering

The Cooperative will furnish, install, own, and maintain a bidirectional meter to measure the kWh usage supplied by the Cooperative to the Member and the kWh supplied by the Member to the Cooperative.

Obligations to Purchase Excess Energy

When the energy generated by the Member’s distributed generation facility exceeds the energy supplied by the Cooperative during the billing period, the Member shall receive a credit for the excess energy pursuant to the Cooperative’s Distributed Generation Purchase Rider, Schedule DG-10 (see Appendix C.)

Charges for Interconnection

The Member generator shall be responsible for all costs of installing, operating, and maintaining

Effective Aug. 1, 2022

protective equipment and/or electrical facilities required to interconnect with the Cooperative's electric distribution system. The Member generator shall be charged for the direct cost incurred by the Cooperative as a result of the interconnection. Said charges will be determined in accordance with the Cooperative's Distributed Generation Purchase Rider (see Appendix C).

Insurance and Indemnification

Member generators will be required to maintain adequate liability coverage and fully indemnify the Cooperative from all liability to the Cooperative and damages to the Cooperative or its Member(s) arising from the operation, maintenance, or use of the distributed generation facility. Coverage limits shall be appropriate for the capacity and other characteristics of the distributed generation facility.

Interconnection Process / Requirements

Submit a completed Distributed Generation Interconnection Application (see Appendix A), including all attachments thereto, at least forty-five (45) days prior to the intended date to interconnect the distributed generation facility to the Cooperative's distribution system.

1. A representative from Coastal Electric Cooperative will review the Application and notify the prospective Member within thirty (30) days if the Application is approved or not approved.
2. Submit:
 - a. Completed Distributed Generation Interconnection Agreement (see Appendix B) once in compliance with all requirements set forth therein, including all applicable safety, power quality, and interconnection requirements established by the National Electric Code, National Electric Safety Code, the Institute of Electrical and Electronic Engineers, and Underwriters Laboratories. The Cooperative may adopt additional safety, power quality, and interconnection requirements.
 - b. Verification that the disconnect switch is installed and operable in compliance with the National Electrical Code, the National Electrical Safety Code, and the Institute of Electrical and Electronics Engineers (including, without limitation, IEEE Standards 1547 and 1547.1).
 - c. Verification that the distributed generation facility is installed and operable in compliance with the requirements established by Underwriters Laboratories or other national testing laboratories.
 - d. Copy of the final, signed, jurisdictional approval (Permit) for the Member's distributed generation facility from any local government entity with jurisdiction over the Member's distributed generation facility (generally the local building and inspection department).

- e. All payments required by and have otherwise complied with the conditions for extension or modification of the Cooperative's distribution system as may be determined herein and as set forth in the Cooperative's Service Rules and Regulations.4. The Cooperative will install metering equipment to measure energy (kWh) delivered by the Cooperative to the Member and the energy delivered from the Member to the Cooperative.
3. The Cooperative will provide written authorization to begin parallel operation of distributed generation.
4. The solar system shall not be activated until the Cooperative's inspection is completed and the Cooperative gives permission to operate (PTO).

Distributed Generation Interconnection Application

Members must not operate their distributed generation facilities in parallel with Coastal Electric Cooperative's system until they have received written authorization for parallel operation from Coastal Electric Cooperative. Unauthorized parallel operation of the Member generating facilities could result in injury to persons and/or damage to equipment or property.

Section 1: Application Information

Name: _____

Mail Address: _____

Facility Address (if different from above): _____

City: _____ State: _____ Zip: _____ Phone Number: _____

Account Number: _____

Email: _____ Fax Number: _____

Contractor (if applicable): _____

Mail Address: _____

City: _____ State: _____ Zip: _____ Phone Number: _____

Representative: _____

Email: _____ Fax Number: _____

Section 2: Generation Facility Information

Generator Type (Check One): Solar _____ Wind _____ Fuel Cell _____ Hydro _____

Other _____

Generator Manufacturer: _____

Generator Model Name and Number: _____

Generator Power Rating (KW/DC): _____

Inverter Manufacturer: _____

Inverter Model Name and Number: _____

Inverter Power Rating (KW/AC): _____

Will the system have battery storage? _____

Storage capacity: _____

Section 3: One-Line Diagram

The Cooperative will provide a one-line diagram indicating the minimum requirements for connectivity. If the Member system varies from requirements, attach a detailed one-line diagram of the proposed generating facility and the interconnection to Coastal Electric Cooperative’s system. Devices such as the service panel, disconnect switch, inverters, generators, circuit breakers, etc., must contain the electrical rating and operating voltages.

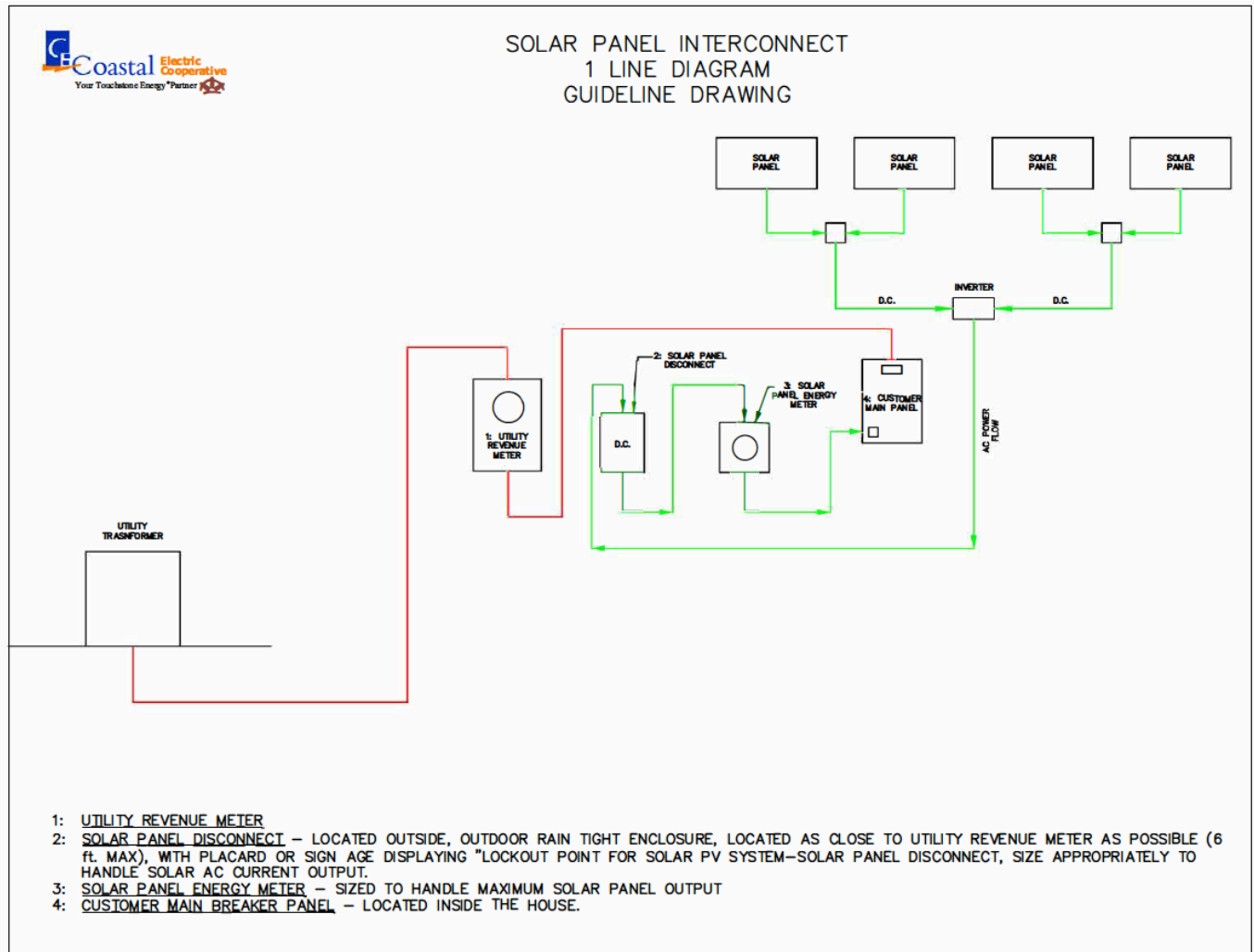

Section 4: Installation Information

Installation Date:_____ Proposed Interconnection Date: _____

I hereby certify that, to the best of my knowledge, all of the information provided in the Application is true and correct.

Signature of Applicant: _____ Date: _____



CONTACTS FOR APPLICATION SUBMISSION AND INFORMATION

Primary Cooperative Contact:

Jason Smith
Energy Advisor

1265 South Coastal Hwy.
P.O. Box 109
Midway, GA 31320

Phone: 912-880-2232

Email: jason.smith@coastalelectric.coop

Secondary Cooperative Contact:

Brian Hayes
Vice President, Engineering and Operations

1265 South Coastal Hwy.
P.O. Box 109
Midway, GA 31320

Phone: 912-880-4027

Email: brian.hayes@coastalelectric.coop

Appendix B

Distributed Generation Interconnection Agreement

This Agreement made _____, 2022, between Coastal Electric Cooperative (hereinafter called "Cooperative"), and _____ (hereinafter called the "Member Generator").

WITNESSETH:

WHEREAS, the Cooperative is a not-for-profit electric membership corporation providing retail electric service; and

WHEREAS, the Member Generator is a Member of the Cooperative; and

WHEREAS, the Member Generator desires to install, own, operate and maintain a renewable resource distributed generation facility primarily intended to supply all or part of its total electric power and energy requirements; and

WHEREAS, the Member Generator desires to interconnect with the Cooperative's electric distribution system (hereinafter called "System") of the Cooperative and has complied with the provisions for interconnection contained in the Cooperative's Distributed Generation Interconnection Policy; and

WHEREAS, the Member Generator desires to operate its generation equipment in parallel with the Cooperative's System.

NOW THEREFORE, it is understood and agreed that the Cooperative shall permit the Member Generator to connect its generation system to the System and to operate its generation equipment in parallel with the System subject to the following terms and conditions:

1. COST OF INTERCONNECTION AND PROTECTIVE EQUIPMENT:

The Member Generator shall be responsible for all costs of installing, operating, and maintaining protective equipment and/or electrical facilities required to interconnect the Member's generation equipment with the System.

2. OPERATING LIMITS:

Operation of Member Generator-owned parallel generating equipment shall not compromise the quality of electric service to other Members on the system. The Member Generator's parallel generating
Effective Aug. 1, 2022

equipment shall meet the following minimum requirements:

a. Voltage

The Member Generator shall be capable of operating its generating equipment at a voltage level of plus/minus 6% of nominal system voltage (120 volts ac). Utility grade negative sequence/under-voltage relaying shall be used to trip the equipment off the line for negative excursions exceeding 8.25% of nominal for a maximum duration of six electrical cycles. Positive excursions exceeding 10% of nominal voltage shall cause the equipment to trip off line. Voltage regulating equipment shall maintain stable excitation levels with negligible hunting (less than 2% of nominal phase current).

b. Flicker

Parallel operation of the generating equipment shall not cause voltage flicker in excess of 2% of nominal line voltage (120 volt ac) as measured at the primary terminals of the Member Generator's generator interface transformer.

c. Frequency

While operating in parallel with the System, the Member Generator must provide a utility grade precision over/under frequency relay calibrated to trip for frequency excursions exceeding plus/minus 0.25 Hz for greater than 10 electrical cycles on a 60 Hz base.

d. Power Factor

Member Generator-owned generation shall employ automatic means of reactive power regulation while operating in parallel with the System. The Member Generator's generating equipment shall be capable of operation within the range of 0.9 lagging to 0.9 leading power factor as required by the Cooperative.

e. Harmonics

Total current harmonic distortion shall not exceed 5.0%. Total voltage harmonic distortion shall not exceed 5.0%, with a limit of 3.0% on any individual harmonic. Special consideration will be given to regenerative drive systems and invertors reviewed on an individual case-by-case basis.

f. Stability

While operating in parallel with the System, the Member Generator's generating equipment shall maintain a stable output level with no noticeable hunting exhibited. In the event a system instability condition arises due to Member Generator-owned generation, it is the Member Generator's responsibility to take measures to rectify the source of instability.

3. GENERATOR INTERFACE TRANSFORMER:

The generator interface transformer is intended to provide isolation of the Member Generator's generating equipment from the System. The inherent impedance of the transformer will minimize the impact on the System due to faults originating at the Member Generator's generation equipment. This transformer may consist of an existing transformer serving the Member Generator's loads or a dedicated transformer dictated by generator or prevailing system characteristics. Interface transformer specifications are determined by the Cooperative and determination of ownership of said transformer shall be at the Cooperative's option.

4. GENERATOR PARALLELING BREAKER:

It is required that a generator-paralleling breaker be of draw-out construction, electrically operated, and rated as a five electrical cycle device for fault clearing or tripping.

5. SYNCHRONIZATION:

It is the Member Generator's responsibility to provide proper synchronizing of its parallel generating equipment. The Cooperative assumes no liability for any Member Generator- owned generation and assumes that the Member Generator operates its equipment at its own risk. Synchronizing equipment shall be capable of matching frequency within plus/minus 0.05 Hz and plus/minus 10 electrical degrees phase angle prior to paralleling breaker closure. Voltage shall be matched within plus/minus 4%.

6. SAFETY:

***** It is not the intent of this document to specify protection of the Member Generator's generator. Protection of the Member Generator's generating equipment is the responsibility of the Member Generator, and the Cooperative assumes no liability for damage to or failure of the Member Generator's generation equipment. *****

- a. Operation of Member Generator-owned generation equipment shall not present a safety hazard to the Cooperative employees or other Members connected to the System or the public at large. Under no circumstances shall the Member Generator-owned generation be used or be capable of energizing a dead System circuit. A positive means of disconnecting and locking out the Member Generator-owned generation equipment with visible air-gap shall be provided to ensure safety of Cooperative operating personnel during line maintenance. This disconnecting means may be via a lockable air-break disconnect or by a lockable draw out circuit breaker. Islanding of the Member Generator-owned generation (a situation whereby the Member Generator's loads and generation remains connected to the bus) shall be prevented by protective relaying specified by the Cooperative based on individual review of the Member

Generator's proposed generating system;

- b. The Member Generator must provide verification that a qualified electrical contractor licensed to practice in Georgia has certified that the required manual disconnect switch has been installed properly; that the distributed generation facility has been installed in accordance with the manufacturer's specifications; and that the installation meets all applicable safety, power quality, and interconnection requirements established by the National Electrical Code, the National Electrical Safety Code, and the Institute of Electrical and Electronics Engineers;
- c. The Member Generator must provide verification that the vendor has certified that the distributed generation facility which has been installed is in compliance with Underwriter's Laboratory UL 1741 standards as "Utility Interactive" (or induction system standards).
- d. The Member Generator must provide verification that the distributed generation facility was inspected and approved by the electrical inspector having legal jurisdiction (generally the local building or inspections department).

7. OUTAGES:

The Member Generator shall not back feed onto the Cooperative's power system during any outage situation. Maintenance outages will occasionally be required on the System, and the Cooperative will provide as much notice and planning as practical to minimize downtime. It is noted that in some emergency cases such notice may not be practical. Compensation will not be made for unavailability of the System due to outages or disconnection of any kind.

8. ACCESS:

The Cooperative shall have access at all times to the Member generator's premises for the purpose of metering reading and performing operations and maintenance activities.

9. INSPECTION / OPERATION / COMPLIANCE PROCEDURE:

The Cooperative reserves the right to inspect the Member Generator's facility at any reasonable time and to immediately disconnect the Member Generator's facility without providing prior notice should it be necessary to address a hazardous condition or failure to comply with the interconnection requirements as specified via this Agreement.

10. INTERCONNECTION CHARGE:

Effective Aug. 1, 2022

The Member Generator shall pay the Cooperative in accordance with the rates, terms, and conditions of the Distributed Generation Purchase Rider attached to and made a part of this Agreement.

11. LIABILITY and INDEMNIFICATION:

The Member Generator shall assume all liability for and shall indemnify the Cooperative and its Members, directors, officers, manager, employees, agents, representatives, affiliates, successors, and assigns for and shall hold them harmless from and against any claims, losses, cost, and expenses of any kind or character to the extent that they result from the Member Generator's design, construction, installation, operation, or maintenance of the Member Generator's generation or interconnection facilities. Such indemnity shall include, but is not limited to, financial responsibility for (a) monetary losses; (b) reasonable cost and expenses of defending an action or claim; (c) damages related to death or injury; (d) damages to property; and (e) damages for the disruption of business.

The Cooperative and Member Generator shall each be responsible for the safe installation, maintenance, repair, and condition of their respective lines, wires, switches, or other equipment or property on their respective sides of the point where the electric energy first leaves the wires or facilities owned by the Cooperative and enters the wires or facilities provided by the Member Generator (the "Point of Interconnection"). The Cooperative does not assume any duty of inspecting the Member Generator's lines, wires, switches, or other equipment or property. The Member Generator assumes all responsibility for the electric service supplied hereunder and the facilities used in connection therewith, at or beyond the Point of Interconnection. The Member Generator acknowledges that the Cooperative cannot prevent voltage fluctuations, surges, or other anomalies on its distribution system, and that such anomalies may result in damage to the distributed generation facility or the Member Generator's other property. The Member Generator hereby accepts all such risks, and agrees to hold the Cooperative harmless from them. As a condition of entering this Agreement, the Member generator agrees to install such protective devices, and to acquire such insurance coverage, as the Member Generator believes are appropriate to protect the Member Generator's property in light of this known risk.

12. INSURANCE

The Member Generator agrees to maintain adequate liability coverage for damages to the Member Generator's facility, other property, and persons who may be damaged by it and to fully indemnify the Cooperative from all liability to the Cooperative and damages to the Cooperative or its Member(s) arising from the operation, maintenance, or use of the distributed generation facility. Coverage limits shall be appropriate for the capacity and other characteristics of the distributed generation facility.

13. NON-OPERATIONAL

The Cooperative will monitor the distributed generation facility for non-performance. If the facility becomes non-operable, the Member Generator will have three (3) years to become operational or the Distribution Generation Interconnection Agreement will become void. Once void, the Member Generator will have to reapply for interconnection with the Cooperative. Due to the aggregate limits on cumulative generating capacity of all renewable resources it is possible the non-performing distributed generation facility will not be approved to rejoin the distributed generation program even if the facility becomes operational.

14. TRANSFER OF OWNERSHIP

If ownership or operational control of the Member Generator's distributed generation facility transfers to any party other than the Member Generator, a new Application and Agreement must be completed by the person or persons taking ownership or operational control of the existing facility. The Cooperative shall be notified in writing no less than thirty (30) days before the Member Generator anticipates transferring ownership or operational control of the distributed generation facility. The person or persons taking over operational control of the distributed generation facility must receive written authorization from the Cooperative for the facility to continue to operate in parallel with the System.

15. TERM:

This Agreement shall become effective on the date first above written and shall remain in effect until one (1) year following the start of the initial billing period and thereafter until terminated by either party giving to the other three (3) months' notice in writing; provided, however, the Cooperative may terminate this Agreement prior to the expiration of the term hereof upon any breach of this Agreement by the Member Generator.

The parties hereto have executed this Agreement all as of the day and year first above written.

Member Generator

Coastal Electric Cooperative

Signature

Signature

Name

Name

Title

Appendix C

DISTRIBUTED GENERATION PURCHASE RIDER DG-10

Effective January 1, 2022

Rate code 31

APPLICABILITY:

Applicable for Members desiring to sell electrical energy to the Cooperative produced by a distributed generation facility, which must be eligible for participation subject to terms and provisions of O.C.G.A. § 46-3-50 et seq. (Georgia Cogeneration and Distributed Generation Act of 2001).

A distributed generation facility must:

1. Be owned and operated by a Member of the Cooperative for production of electrical energy, and
2. Be located on the Member's premises, and
3. Be connected to and operate in parallel with the Cooperative's distribution facilities, and
4. Be intended primarily to offset part or all of the Member generator's requirement for electricity, and
5. Have peak generating capacity of not more than 10 kW for residential applications.
6. Use solar photovoltaic system, fuel cell or wind generation

AVAILABILITY:

Throughout the Cooperative's service area, in accordance with the Cooperative's Service Rules and Regulations.

TYPE OF SERVICE:

Single-phase service, 60 hertz, at the following standard voltages: 120/240 or other voltages as might be mutually agreeable.

Effective Aug. 1, 2022

METERING:

The Cooperative will install bi-directional metering. Bi-directional metering is defined as measuring the amount of electricity supplied by the Cooperative and the amount fed back to the Cooperative by the Member's distributed generation facility during the billing period using the same meter. Bi-directional metering shall be used where distributed generation facilities are connected to the Cooperative distribution system on the Member's side of the Member's meter.

AVOIDED ENERGY COST:

Per kilowatt-hour \$0.0351

As the avoided energy cost can change from year to year, this document will be updated each calendar year to reflect any changes with the avoided cost.

PAYMENTS FOR ENERGY:

Payments for power purchased from distributed generation shall be as described below.

Whenever the Member's consumption exceeds electricity generated by the Member's distributed generation, that electricity is supplied by the Cooperative. All electricity supplied by the Cooperative shall be billed by the Cooperative in accordance with residential tariff RS-8.

Whenever the electricity generated by the Member's distributed generation system exceeds the Member's consumption, the Member shall be billed under residential tariff RS-8 for the Basic Facilities Charge for that billing period and credited for excess kWh generated during the billing period at Avoided Energy Cost, with this kWh credit appearing on the bill for the billing period.

In the event a Member develops a credit balance during a billing period, the credit balance will be applied to the next month's billing charges.

The Cooperative will only be required to purchase energy from eligible distributed generation facilities on a first-come, first-served basis until cumulative generating capacity of all renewable energy sources from all Members equals 0.2% of the Cooperative's annual peak demand in the previous year.

Effective Aug. 1, 2022

SAFETY, POWER QUALITY AND INTERCONNECTION REQUIREMENTS:

The Member shall be responsible for ensuring a safe and reliable interconnection with the Cooperative system and all costs incurred therein. The Cooperative has available, upon request, a Bulletin setting forth criteria for interconnection including system protection requirements, power quality and operating guidelines. The Member should be familiar with the Bulletin and follow all procedures. Each interconnection request is handled individually by the Cooperative.